



KT-BPLED40-14-8XX-VDIM

BACKLIT LED PANEL LIGHT

DESCRIPTION

1'x4' LED panel light, 40W, 120-277V input, 0-10V dimming

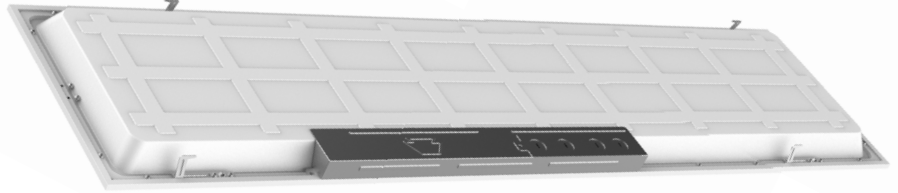

PRODUCT FEATURES

- Aluminum frame featuring stepped edge design detail and gloss white paint for improved aesthetics
 - New backlit style design; fits standard T-grid ceilings
 - Suitable for recessed or surface mount (with optional accessories)*
 - Construction features precise optical lenses over each individual LED, offering optimal light diffusion and consistent surface illumination, with no risk of yellowing over product lifetime
 - Suitable for damp locations
 - Powered by Keystone 0-10V dimmable LED driver with built-in junction box
 - Compatible with Keystone SmartSafe LED emergency backup
 - Over 50% energy savings compared to traditional fluorescent troffers
 - Operating temp range -20°C/-4°F to 40°C/104°F
- * For use in non-fire rated installations only

PERFORMANCE SPECIFICATIONS

Catalog Number	Input Voltage	Wattage	Color Temperature	Lumen Output	CRI	Power Factor	Efficacy	Lifetime
KT-BPLED40-14-835-VDIM	120-277V	40W	3500K	4,400	>80	>0.9	110 lm/W	50,000 Hours
KT-BPLED40-14-840-VDIM	120-277V	40W	4000K	4,400	>80	>0.9	110 lm/W	50,000 Hours
KT-BPLED40-14-850-VDIM	120-277V	40W	5000K	4,400	>80	>0.9	110 lm/W	50,000 Hours

PHOTOMETRIC SPECIFICATIONS

ISOCANDELA PLOT

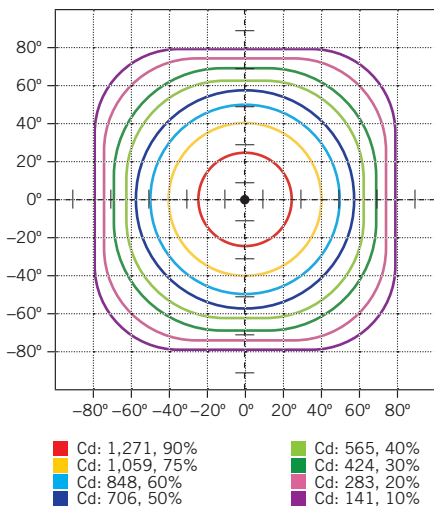

POLAR CANDELA DISTRIBUTION

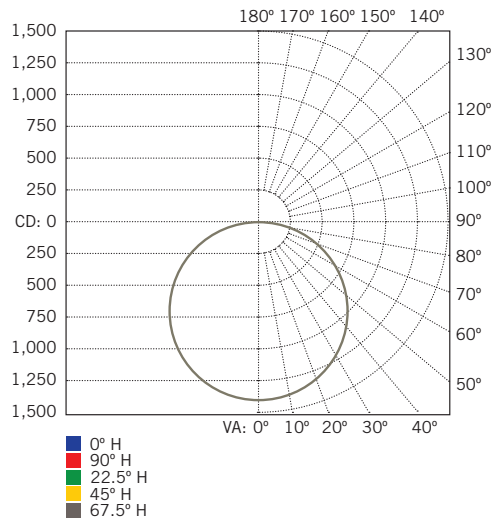

ZONAL LUMEN SUMMARY

Zone	Lumens	% Luminaire
0-30	1,105.0	26.4%
0-40	1,818.0	43.4%
0-60	3,244.7	77.5%
60-90	934.3	22.3%
70-100	408.1	9.7%
90-120	3.9	0.1%
0-90	4,179.0	99.8%
90-180	9.8	0.2%
0-180	4,188.8	100%

KT-BPLED40-14-8XX-VDIM
BACKLIT LED PANEL LIGHT

PHYSICAL SPECIFICATIONS

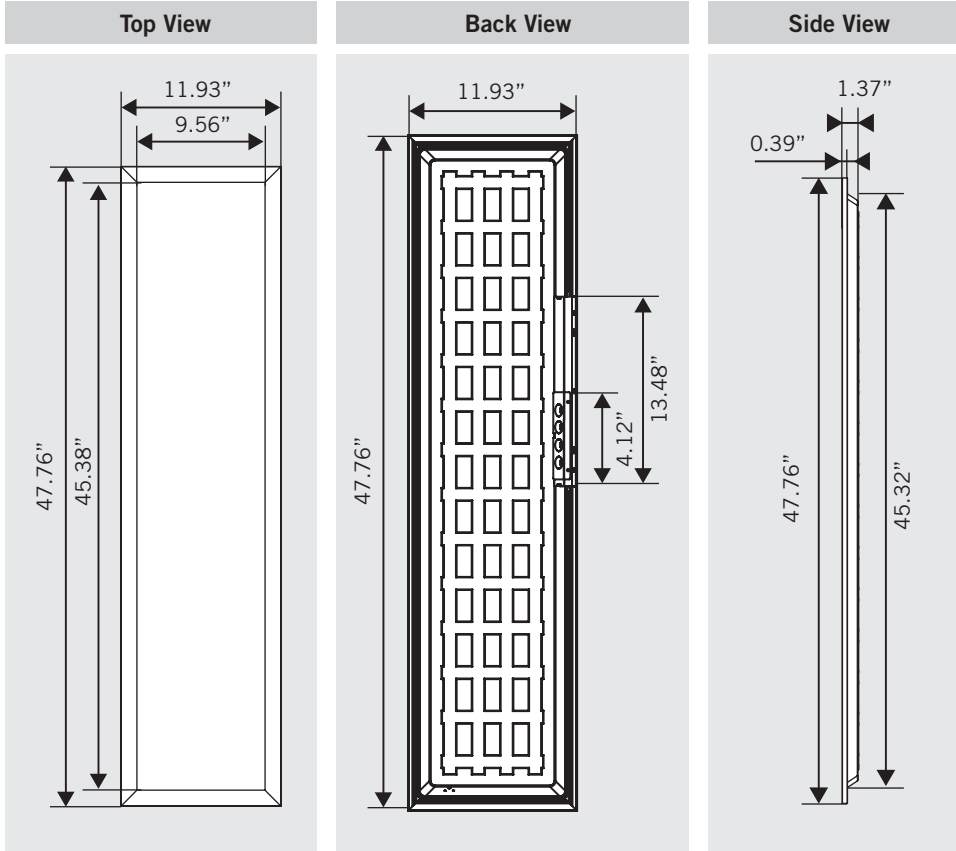

WEIGHT INFORMATION

1 Piece	1 Carton
6.2 lbs	12.4 lbs

EXPLODED VIEW

CONSTRUCTION FEATURES

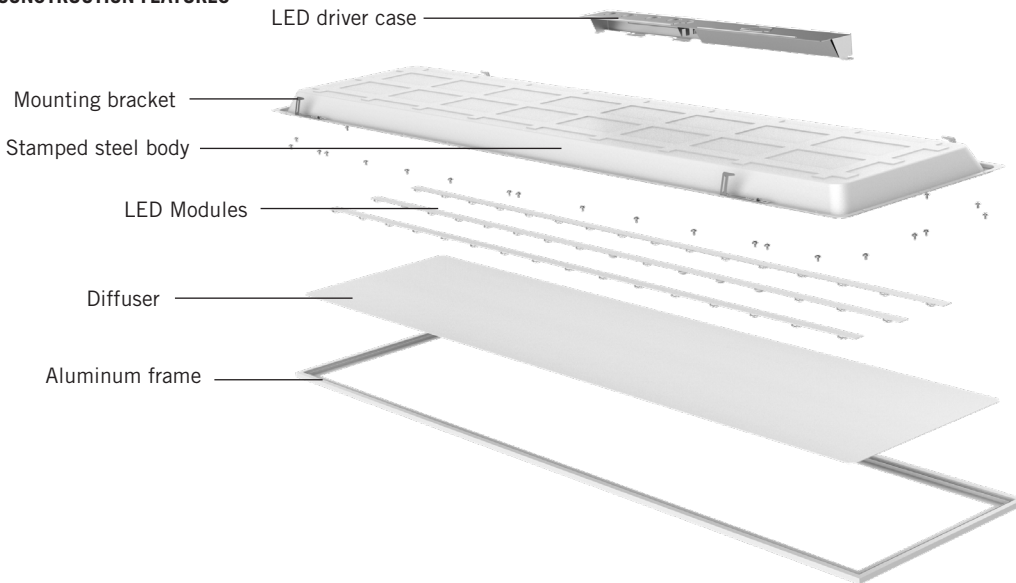



KT-BPLED40-14-8XX-VDIM

BACKLIT LED PANEL LIGHT

WIRELESS CONTROL OPTIONS

Brand / System	Description	Ordering Number
Lutron Vive	FCJS-010 Wireless 0-10V fixture controller; 1A Max load; factory installed	KT-BPLED40-14-8XX-VDIM /FCJS0



ACCESSORIES (SOLD SEPARATELY)

Accessory	Catalog Number	Description
Emergency Battery Backup Mounting Kit	KT-BPLED-EM-14-KIT	Mounting Bracket for SmartSafe LED emergency backup for 1x4 backlit panels
Surface Mount Kit	KT-BPLED-SM-14-KIT	Surface Mount Kit 1x4 Backlit panels
J-Box	KT-BPLED-JBOX-1	Larger J-Box add-on for LED Backlit Panels, DLC Standard

ORDERING INFORMATION

CATALOG NUMBER	CARTON QTY.	EASY CODE	UPC
KT-BPLED40-14-835-VDIM	2	PIM-68	843654127835
KT-BPLED40-14-840-VDIM	2	PYY-43	843654127842
KT-BPLED40-14-850-VDIM	2	PEB-32	843654127859

CATALOG NUMBER BREAKDOWN

KT-BPLED40-14-8XX-VDIM

1 **2** **3** **4** **5** **6** **7** **8**

- 1** Keystone Technologies
- 2** Backlit Panel Light LED Fixture
- 3** Wattage
- 4** 1' x 4' Nominal Size
- 5** 800 Series
- 6** Color Temperature
- 7** 0-10V Dimming
- 8** Sensor Options

8 Sensor Options

	No option
/FC1-PIR	Occupancy sensor included